

ORV 30 K 4000 P4LK

Retroreflective Sensor

- Small design
- Red light
- 12-turn potentiometer
- Sensitivity adjustable, large operating distance
- Polarized filter

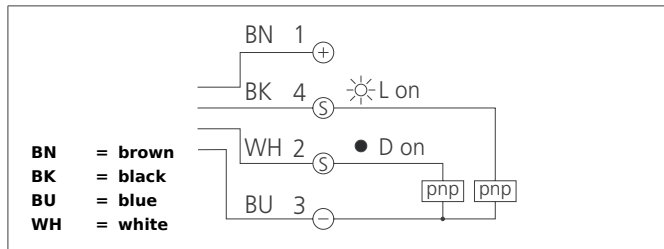
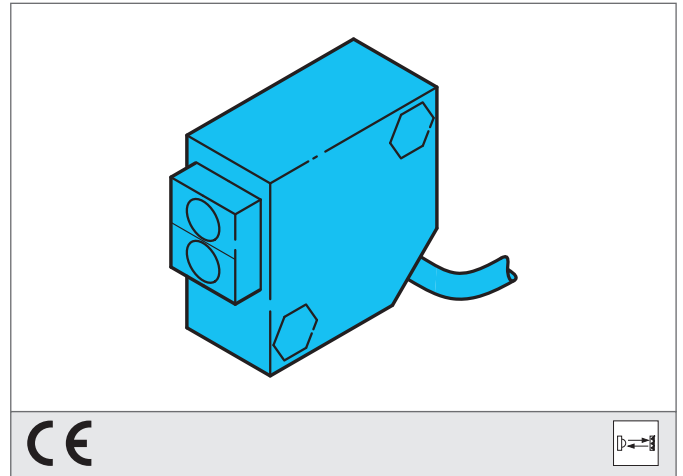

Safety instructions

The Instruments are not to be used for safety applications, in particular applications in which safety of persons depends on proper operation of the instruments.
These instruments shall exclusively be used by qualified personnel.

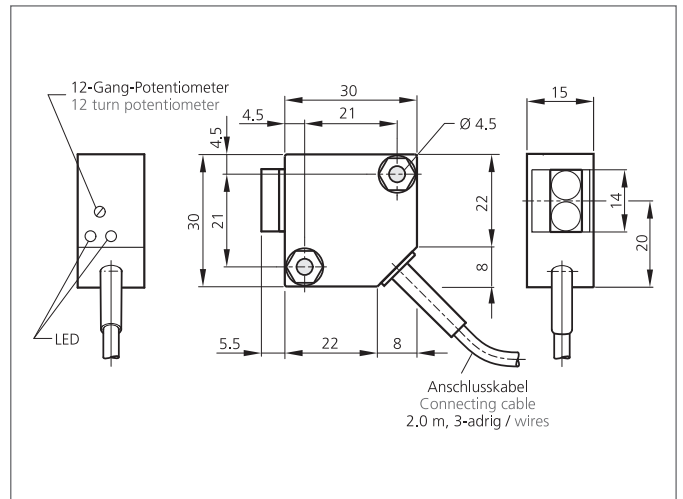

TECHNICAL INFORMATION (typ.)		+20°C, 24V DC
Operating principle		Retroreflective sensor
Evaluation		digital
Size		30 x 30 x 15 mm (Dimensions)
Design		cuboid design
Characteristics		Integrated polarized filter
Emitted light		Red, 660 nm, clocked
Operating distance		200 ... 4.000 mm adjustable
Service voltage		10 ... 36 V DC
Internal power consumption		< 20 mA
Sensitivity adjustment		Potentiometer 12-way
Referring reflector		Ø 84 mm, R 84
Switching output		pnp, 200 mA, exclusive OR
Switching hysteresis		< 10 %
Voltage drop		< 2,0 V
Switching frequency		1.000 Hz
Response-/release time		< 0,5 ms / < 0,5 ms
Ambient temperature		-25 ... +55 °C
Ambient light immunity		10 kLx
Insulation voltage endurance		500 V
Protection class		IP 67
Protection degree		III, operation on protective low voltage
Casing material		plastics (PBT)
Material		glass (Window)

ORV 30 K 4000 P4LK
Retroreflective Sensor



TECHNICAL INFORMATION (typ.)

Connection

+20°C, 24V DC

cable PVC, 2 m, 3-poled